

**Questions are for both separate science and combined science students  
unless indicated in the question**

- 1 The apparatus in the diagram is used to heat a sample of hydrated copper(II) sulfate crystals,  $\text{CuSO}_4 \cdot 5\text{H}_2\text{O}$

The equation for the reaction that takes place is

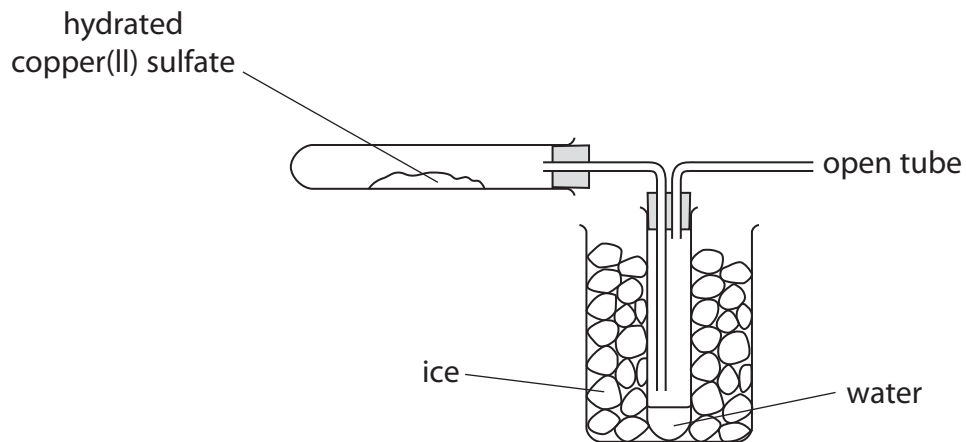

- (a) Draw an arrow on the diagram to show where heat is applied. (1)

- (b) What is the purpose of the ice? (1)

- 
- (c) Calculate the maximum mass of water that could be collected when a sample of hydrated copper(II) sulfate of mass 2.50 g is heated.  
[ $M_r$  of  $\text{CuSO}_4 \cdot 5\text{H}_2\text{O}$  is 250] (3)

mass of water = ..... g

**(Total for Question 1 = 5 marks)**

---

2 Potassium hydrogencarbonate ( $\text{KHCO}_3$ ) decomposes on heating.

Three possible equations for the decomposition are

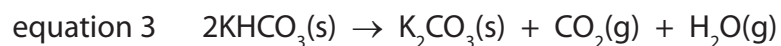
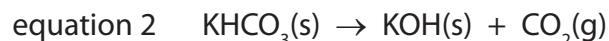
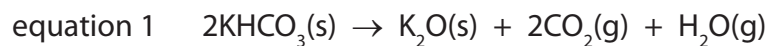

When 8.00 g of potassium hydrogencarbonate is heated until it is fully decomposed, 5.52 g of solid is formed.

(a) Complete the table by calculating the amount, in moles, of each solid.

(2)

Solid	$M_r$ of solid	Mass of solid in g	Amount of solid in mol
$\text{KHCO}_3$	100	8.00	
$\text{K}_2\text{O}$	94	5.52	
KOH	56	5.52	
$\text{K}_2\text{CO}_3$	138	5.52	

(b) Use the information in the table to explain which equation, 1, 2 or 3, represents the decomposition of potassium hydrogencarbonate.

(2)

.....

.....

.....

.....

.....

.....

.....

**(Total for Question 2 = 4 marks)**

3 A student used this apparatus to make and collect a sample of hydrogen gas.

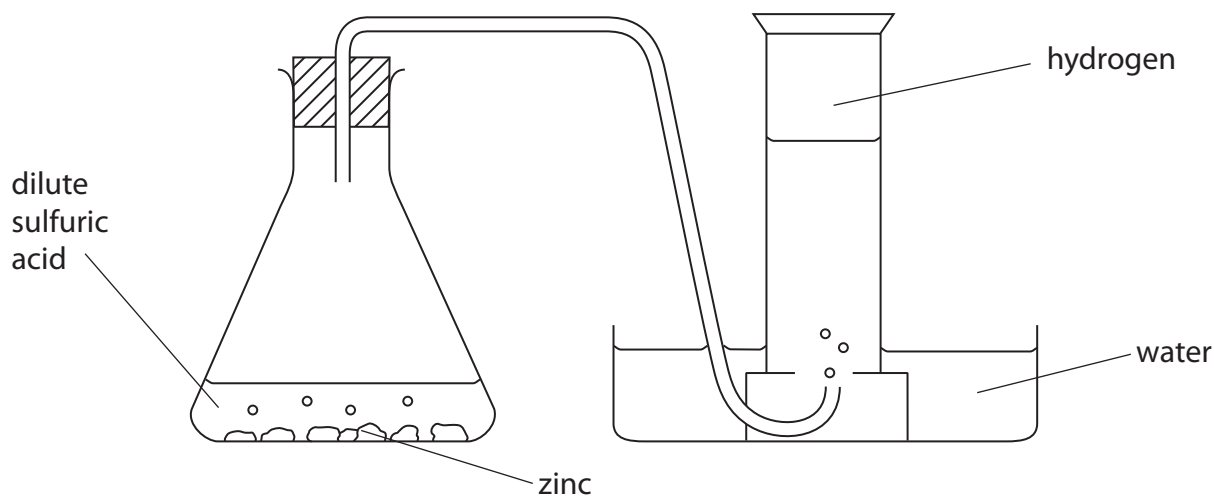

(a) The reaction in the flask can be shown by this word equation.

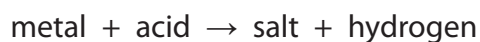

(i) The name of the salt formed in the student's experiment is

(1)

- A zinc sulfate
- B zinc sulfide
- C zinc sulfite
- D zinc sulfur

(ii) The student could have used other metals in this experiment.

Place crosses (☒) in **two** boxes to show the names of two other metals that could be safely used to make hydrogen.

(2)

- A copper
- B iron
- C magnesium
- D potassium
- E silver

(b) Describe a test to show that the gas collected is hydrogen.

(1)

(c) Water is formed when hydrogen combines with oxygen.

Balance the equation for this reaction.

(1)



(d) Equation 1 represents a reaction using cobalt(II) chloride that can be used to show a liquid contains water.

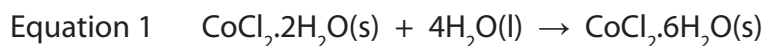

In this reaction there is a colour change from blue to pink.

(i) Which word describes **both** cobalt compounds in equation 1?

(1)

- A anhydrous
- B aqueous
- C hydrated
- D saturated

(ii) When the product in equation 1 is gently heated, another reaction occurs. Equation 2 represents this reaction.

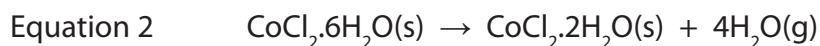

What do equations 1 and 2 suggest about the reactions?

(1)

---

**(Total for Question 3 = 7 marks)**

---

4 The piece of apparatus shown contains  $0.010 \text{ mol/dm}^3$  hydrochloric acid.

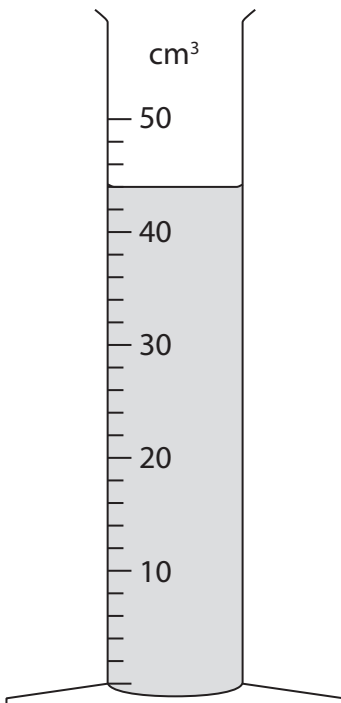

(a) (i) Give the name of this piece of apparatus.

(1)

(ii) What volume of hydrochloric acid is in the apparatus?

(2)

(iii) Use your answer in (a)(ii) to calculate the amount, in moles, of hydrochloric acid in the apparatus. **(separate only)**

(2)

Amount = ..... mol

- (b) A student poured a solution containing 0.010 mol of hydrochloric acid into a beaker. He then added 0.0075 mol of zinc powder and collected the hydrogen given off in a gas syringe.

The equation for the reaction is



Is the zinc or the hydrochloric acid in excess? Explain your answer.

(2)

.....

.....

.....

- (c) The student repeated the experiment with 0.0075 mol of magnesium powder with the same total surface area as the zinc.

The equation for the reaction is

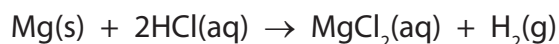

- (i) What effect would this change have on the rate at which the hydrogen is given off?

(1)

.....

.....

.....

- (ii) What effect would this change have on the volume of hydrogen produced?

(1)

.....

.....

.....

---

**(Total for Question 4 = 9 marks)**

- 5 A student carries out an investigation into the reaction between magnesium carbonate and dilute sulfuric acid. He uses this apparatus.

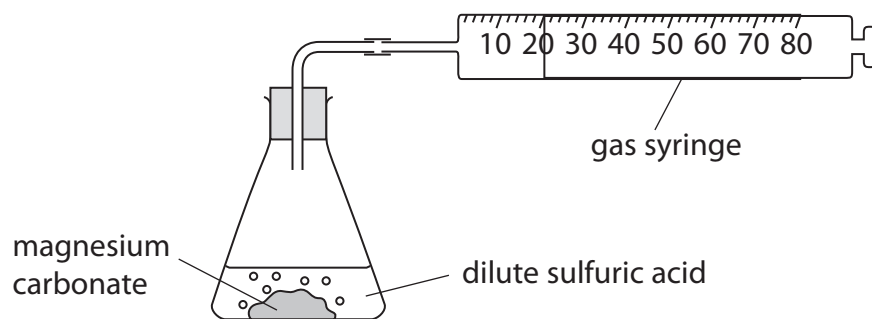

The student carries out seven experiments. In each experiment he uses the same mass of magnesium carbonate but a different volume of acid. He measures the total volume of carbon dioxide collected in each experiment. The table shows his results.

Volume of sulfuric acid used in $\text{cm}^3$	0	5	15	20	25	30	35	40
Volume of carbon dioxide collected in $\text{cm}^3$	0	16	47	61	64	78	80	80

- (a) Plot the results on the grid and draw a curve of best fit.

(3)

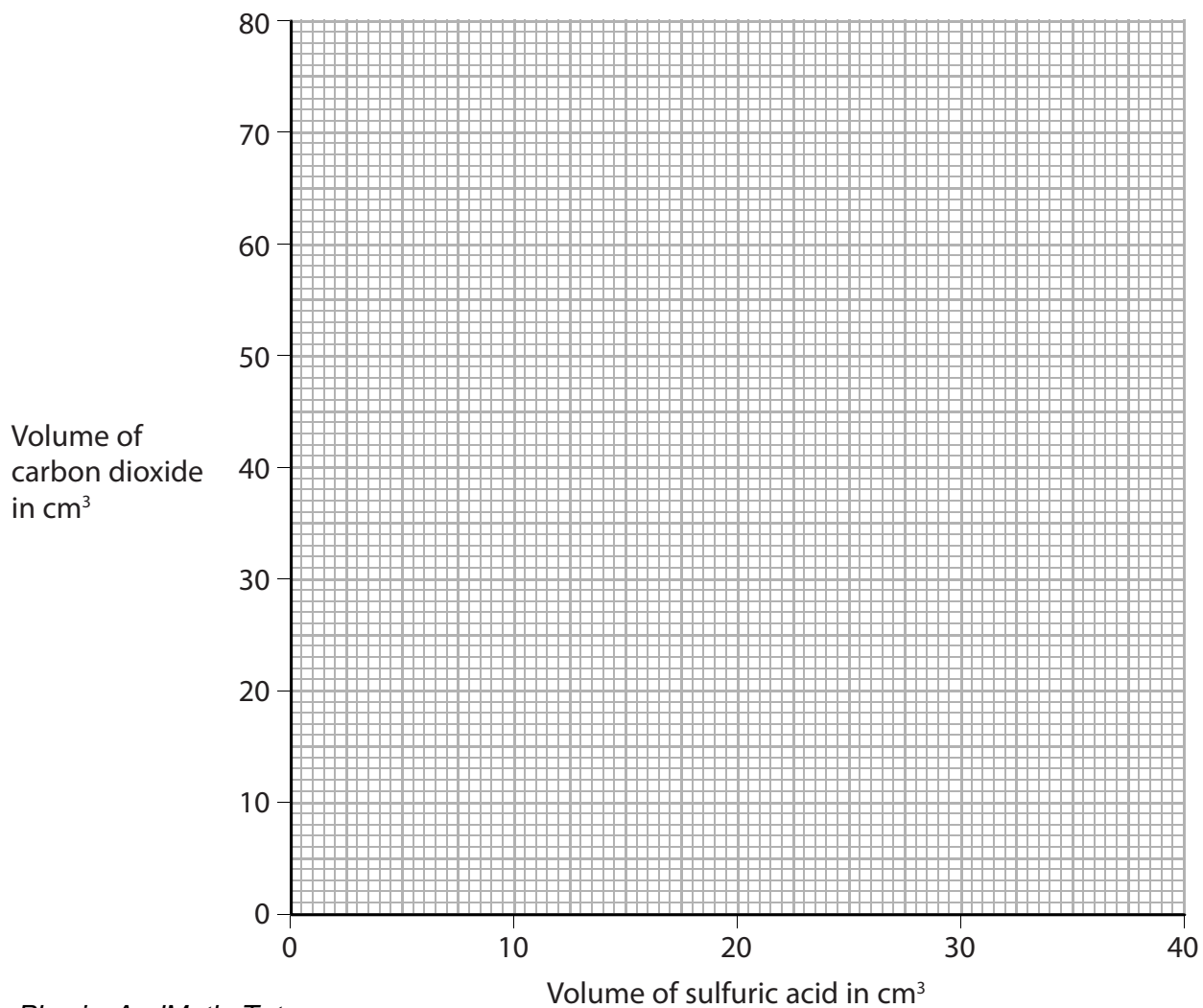

(b) (i) Which volume of sulfuric acid produces an anomalous result?

(1)

.....  
(ii) Explain what the results with 35 cm<sup>3</sup> and 40 cm<sup>3</sup> of sulfuric acid indicate about the reaction.

(2)

.....  
.....  
.....  
(iii) Use the graph to find the volume of carbon dioxide that would be collected if 10 cm<sup>3</sup> of acid were used.

(1)

volume of carbon dioxide = ..... cm<sup>3</sup>

(iv) Use the graph to find the volume of sulfuric acid that would result in 55 cm<sup>3</sup> of carbon dioxide being collected.

(1)

volume of sulfuric acid = ..... cm<sup>3</sup>

**(Total for Question 5 = 8 marks)**

---



6 In 1774, the scientist Joseph Priestley produced oxygen by heating mercury(II) oxide, (HgO). When heated, mercury(II) oxide breaks down into its elements.

(a) (i) Write a chemical equation for the breakdown of mercury(II) oxide into its elements. (1)

---

(ii) What name is given to this type of reaction? (1)

---

(b) Priestley's method of producing oxygen is no longer used because of the high toxicity of mercury and mercury compounds.

A student prepares oxygen by adding hydrogen peroxide solution to solid manganese(IV) oxide.

The diagram shows the apparatus used.

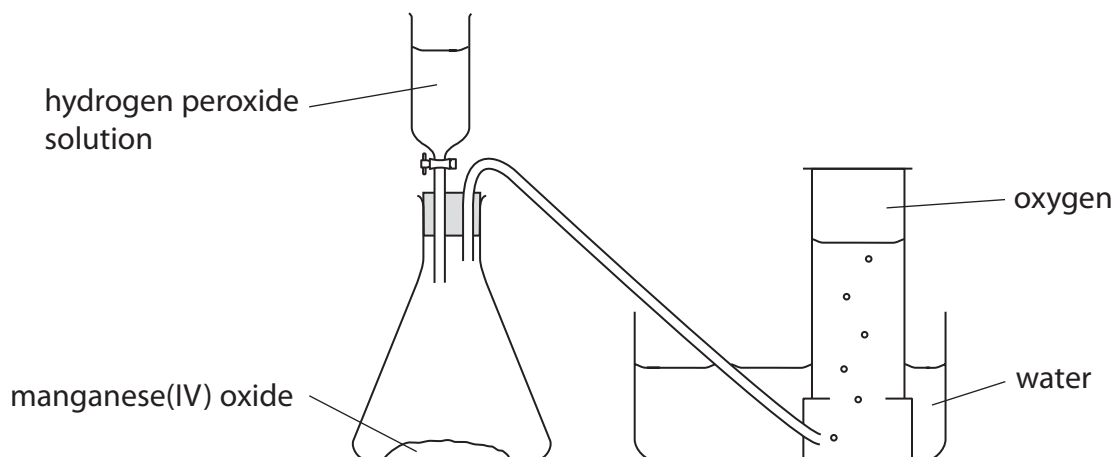

The equation for the reaction is

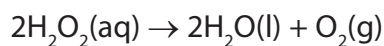

(i) Give the name of the apparatus that contains the hydrogen peroxide solution. (1)

---

(ii) Suggest how the first sample of gas collected may be different from the samples collected later. (1)

---

---

---

(c) A catalyst increases the rate of decomposition of the hydrogen peroxide.

Describe a method you could use to show that the manganese(IV) oxide is acting as a catalyst in this reaction.

(4)

.....

.....

.....

.....

.....

.....

.....

.....

.....

.....

.....

.....

.....

.....

.....

.....

.....

.....

.....

.....

.....

.....

(d) Sulfur burns in oxygen to produce sulfur dioxide (SO<sub>2</sub>).

Sulfur dioxide is very soluble in water.

(i) Write a chemical equation for the reaction that takes place when sulfur dioxide dissolves in water.

(1)

.....

(ii) Universal indicator is added to the solution formed in (d)(i).

Explain the effect that the solution has on the universal indicator.

(2)

.....

.....

.....

.....

.....

.....

.....

.....

.....

.....

**(Total for Question 6 = 11 marks)**